

P.C.B LAYOUT

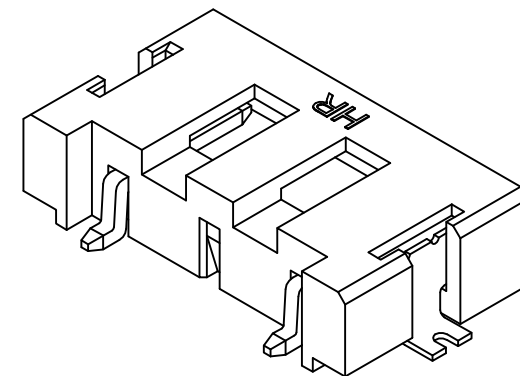



Ordering code

A3800 WR-SF-03P DQ2
 ① ② ③ ④ ⑤

- ① Series No.
- ② Connector type: WR=Right angle
- ③ Mounting type: SF=SMT with boss
- ④ No. of circuits
- ⑤ Option code:
 DQ2=Contacts/Gold-flash and
 Solder tabs/Gold-flash; Cut #2-pin

SPECIFICATIONS

Current Rating: 1A AC,DC
 Voltage Rating: 1400V AC,DC
 Temperature Range: $-25^{\circ}\text{C} \sim +85^{\circ}\text{C}$
 Contact Resistance: 20m Ω Max.
 Insulation Resistance: 1000M Ω Min.
 Withstanding Voltage: 3800V AC/minute
 Pin Material: Brass/Gold-flash
 Solder Tabs: Brass/Gold-flash
 Material: Nylon 6T,UL94V-0
 Color: Natural(Beige)

						燦達電子工業股份有限公司 JOINT TECH ELECTRONIC IND. CO., LTD.	
UNIT	SCALE	SHEET	TITLE:				
mm		1 of 2					
DRAWN BY	APPROVED BY						
歐陽小強	董正一						
2006.12.11	2006.12.11						
GENERAL TOLERANCE							
A1	EN1001190045	2010.01.15	X.X ± 0.25	ANGLE \pm			
A0	NEW RELEASE	2006.12.11	X.XX ± 0.15				
REV.	DESCRIPTION	DATE	X.XXX ± 0.05				
					DRAW NO.:		REV.
					A3800WR-SF-03PDQ2		A1

3.80mm PITCH
 90° WAFER-SMT TYPE

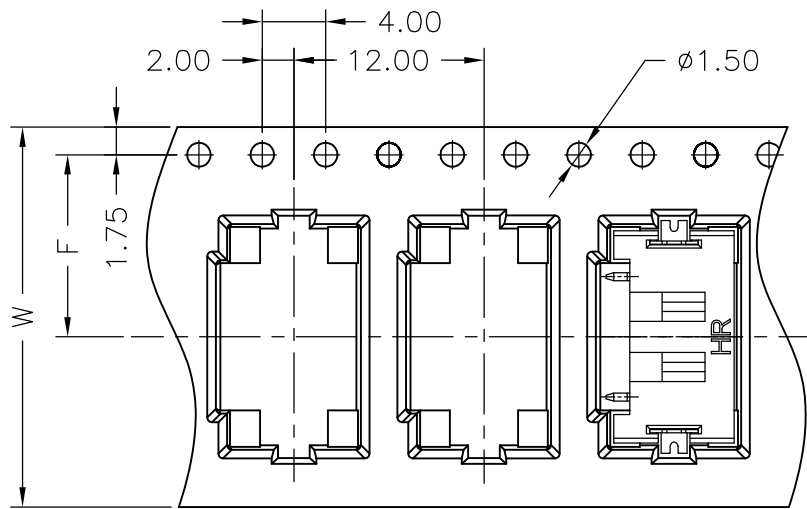

Unreeling direction →

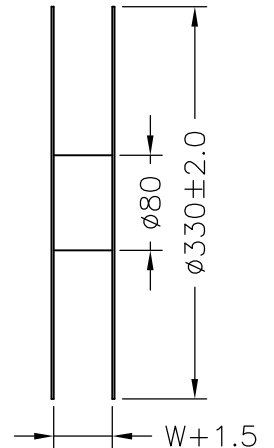
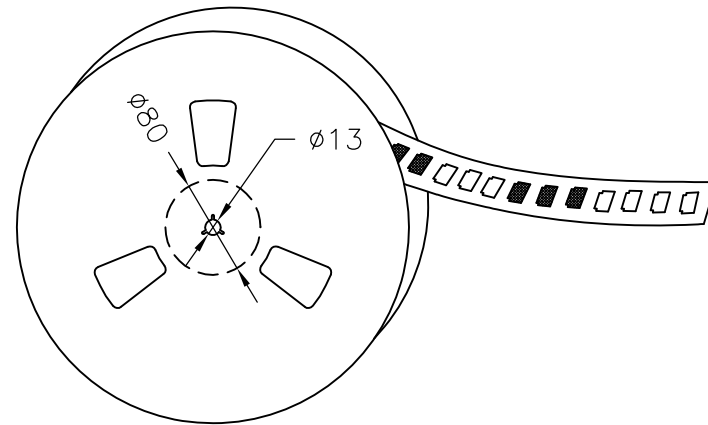
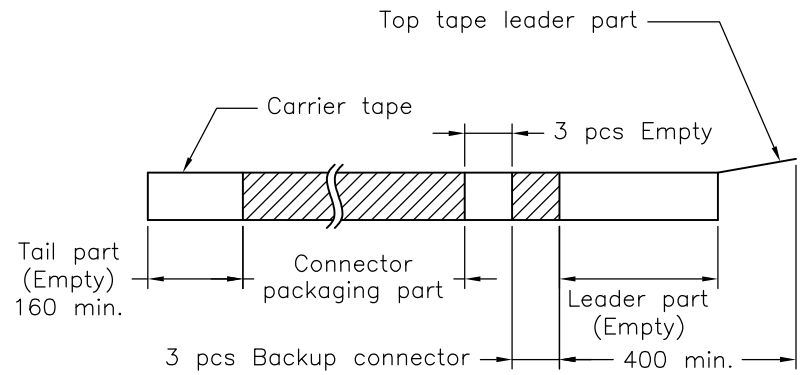
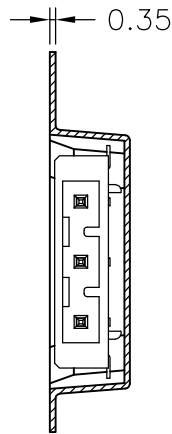
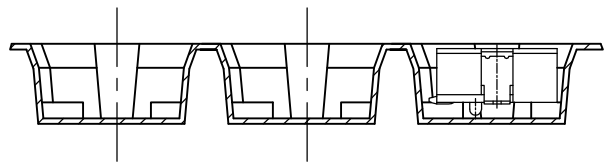

Number of Contacts	W±0.3	F±0.1	S±0.1	Q'ty/Reel
03P	24	11.50	---	1,000

 燦達電子工業股份有限公司 JOINT TECH ELECTRONIC IND. CO., LTD.				UNIT	SCALE	SHEET	TITLE:
				mm		2 of 2	
DRAWN BY		APPROVED BY		GENERAL TOLERANCE		3.80mm PITCH 90° WAFER-SMT TYPE, TAPING SPEC.	
歐陽小強		董正一					
2006.12.11		2006.12.11					
REV.		DATE		DRAW NO.:			
A1	EN1001190045	2010.01.15	X.X±0.25	ANGLE±	A3800WR-SF-03PDQ2		A1
A0	NEW RELEASE	2006.12.11	X.XX±0.15				
			X.XXX±0.05				