

21P~30P
SCALE 0.8:1

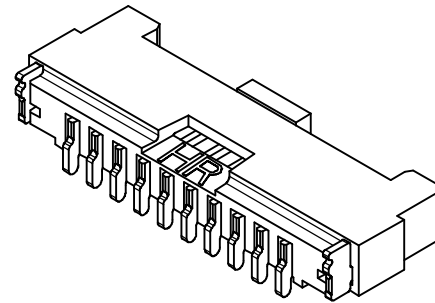

SPECIFICATIONS
 Current Rating: 1A AC,DC
 Voltage Rating: 150V AC,DC
 Temperature Range: -25°C ~ +85°C
 Contact Resistance: 30mΩ Max.
 Insulation Resistance: 500MΩ Min.
 Withstanding Voltage: 500V AC/minute
 Pin Material: Brass/Tin-plated
 Solder Tabs: Brass/Tin-plated
 Material: Nylon 6T,UL94V-0
 Color: Natural(Beige)

Ordering Information & Dimensions

PART NO.	Dimensions	
	A	B
A1253WVA-S-02P	1.25	7.45
A1253WVA-S-03P	2.50	8.70
A1253WVA-S-04P	3.75	9.95
A1253WVA-S-05P	5.00	11.20
A1253WVA-S-06P	6.25	12.45
A1253WVA-S-07P	7.50	13.70
A1253WVA-S-08P	8.75	14.95
A1253WVA-S-09P	10.00	16.20
A1253WVA-S-10P	11.25	17.45
A1253WVA-S-11P	12.50	18.70
A1253WVA-S-12P	13.75	19.95
A1253WVA-S-13P	15.00	21.20
A1253WVA-S-14P	16.25	22.45
A1253WVA-S-15P	17.50	23.70
A1253WVA-S-20P	23.75	29.95
A1253WVA-S-25P	30.00	36.20
A1253WVA-S-30P	36.25	42.45

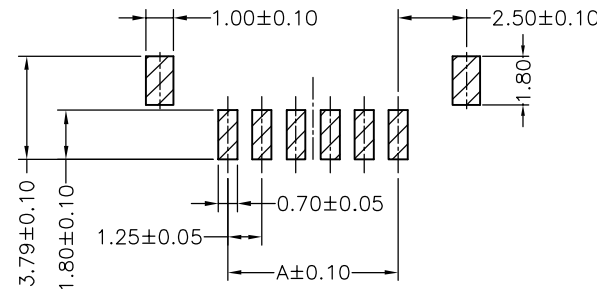
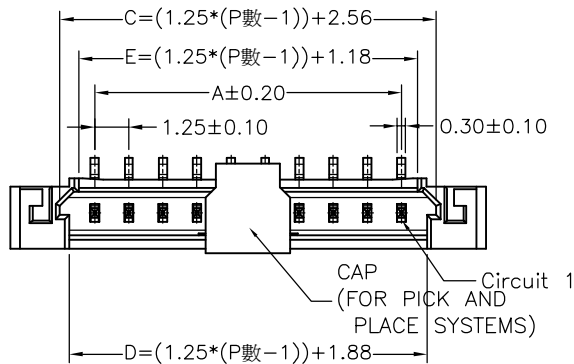

P.C.B. LAYOUT

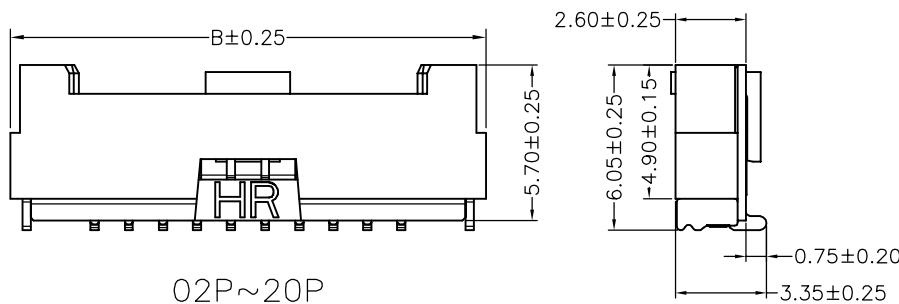

02P~20P

				JOINT TECH ELECTRONIC IND. CO., LTD. JOY DAY INDUSTRIAL CO., LTD.	
UNIT	SCALE	SHEET	TITLE:		
mm		1 of 2	1.25mm PITCH 180° WAFER-SMT TYPE, ULTRA LOW PROFILE, WITHOUT BOSS		
DRAWN BY 歐陽小強 2007.12.26		APPROVED BY 謝瑞清 2007.12.26			
GENERAL TOLERANCE					
A1	REVISE	2008.03.13	X.X±0.25	ANGLE±	
A0	NEW RELEASE	2007.12.26	X.XX±0.15	DRAW NO. : A1253WVA-S-XP	
REV.	DESCRIPTION	DATE	X.XXX±0.05		

REV. A1

02~11 Contacts

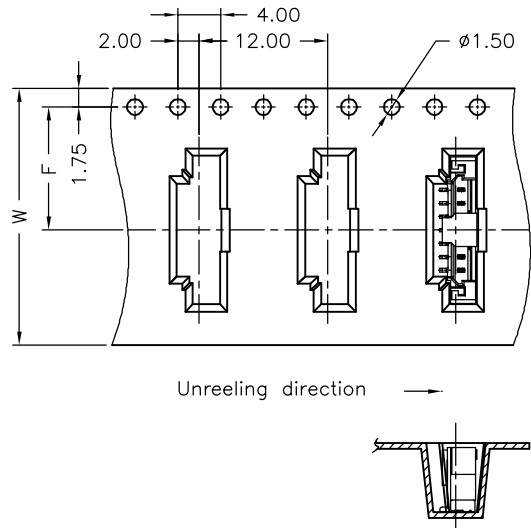

12~30 Contacts

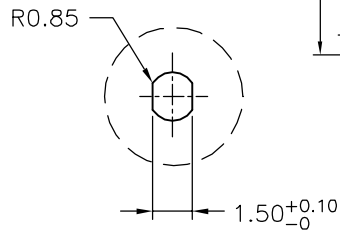
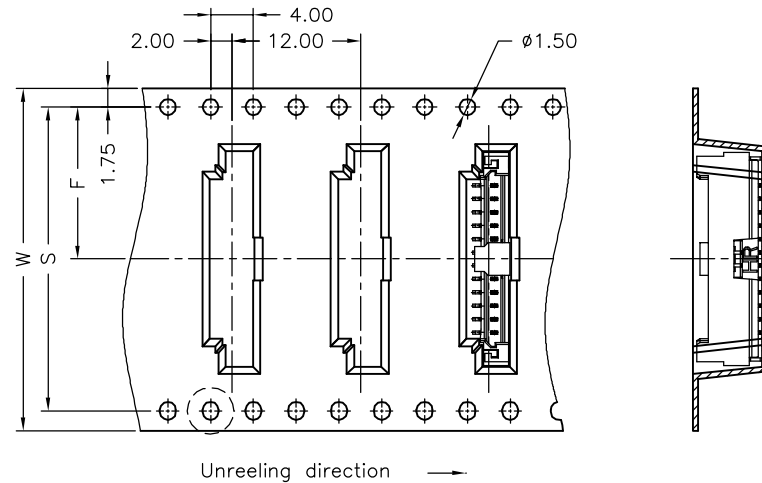

Number of Contacts	W±0.3	F±0.1	S±0.1	Q'ty/Reel
02P	16	7.50		1,000
03P	16	7.50		1,000
04P	16	7.50		1,000
05P	16	7.50		1,000
06P	24	11.50		1,000
07P	24	11.50		1,000
08P	24	11.50		1,000
09P	24	11.50		1,000
10P	24	11.50		1,000
11P	24	11.50		1,000
12P	32	14.20	28.40	1,000
13P	32	14.20	28.40	1,000
14P	32	14.20	28.40	1,000
15P	32	14.20	28.40	1,000
20P	44	20.20	40.40	1,000
25P	44	20.20	40.40	1,000
30P	56	26.20	52.40	1,000

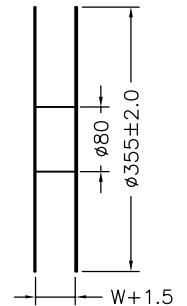
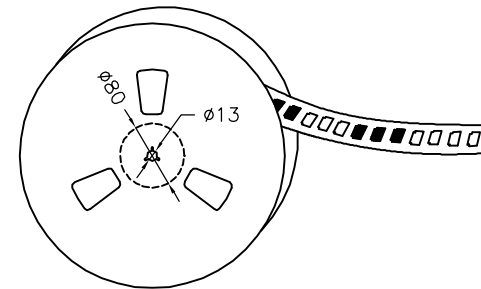
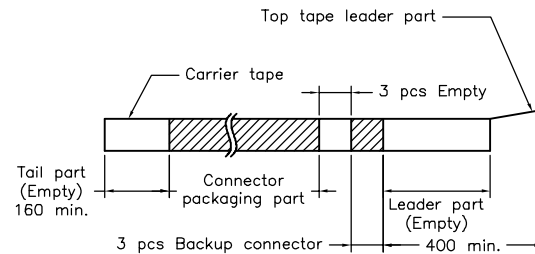

				UNIT	SCALE	SHEET	TITLE: 1.25mm PITCH 180° WAFER-SMT TYPE, WITHOUT BOSS TAPING SPEC.
				mm		2 of 2	
DRAWN BY				APPROVED BY		DRAW NO. : A1253WVA-S-XP	
歐陽小強				謝瑞清			
2007.12.26				2007.12.26			
GENERAL TOLERANCE				ANGLE±		REV. A1	
A1	REVISE	2008.03.13	X.X±0.25				
A0	NEW RELEASE	2007.12.26	X.XX±0.15				
REV.	DESCRIPTION	DATE	X.XXX±0.05				