

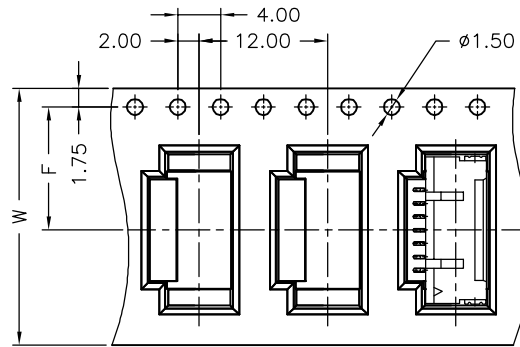

### 02~07 Contacts

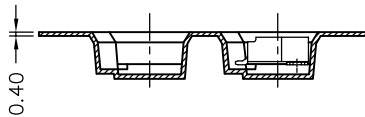

Unreeling direction →



### 08~30 Contacts

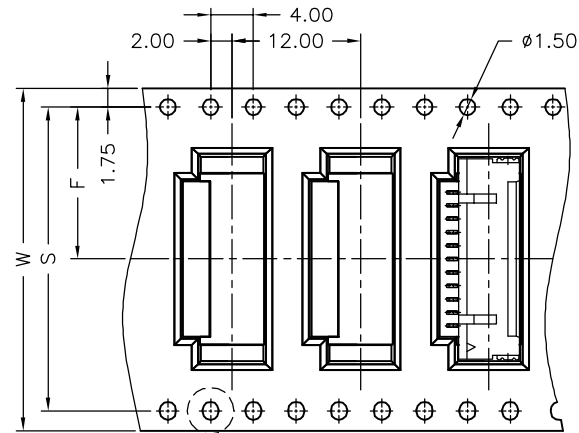

Unreeling direction →

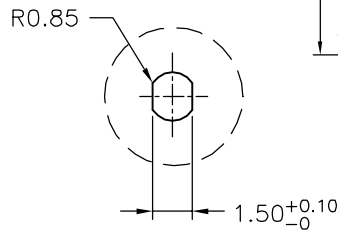
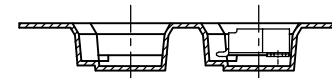

Top tape leader part

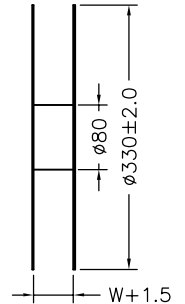
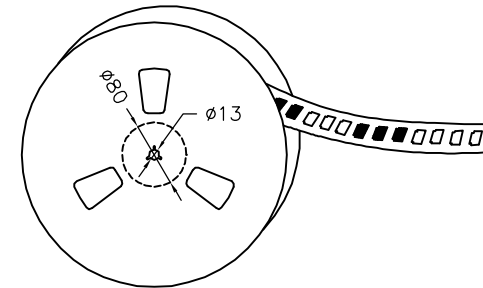
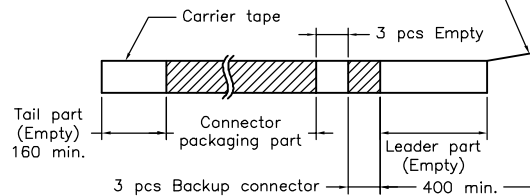

Number of Contacts	W±0.3	F±0.1	S±0.1	Q'ty/Reel
02P	16	7.50	/	1,000
03P	24	7.50		1,000
04P	24	11.50		1,000
05P	24	11.50		1,000
06P	24	11.50		1,000
07P	24	11.50		1,000
08P	32	14.20		28.40
09P	32	14.20	28.40	1,000
10P	32	14.20	28.40	1,000
11P	32	14.20	28.40	1,000
12P	32	14.20	28.40	1,000
13P	44	14.20	28.40	1,000
14P	44	20.20	40.40	1,000
15P	44	20.20	40.40	1,000
20P	44	20.20	40.40	1,000
21P	44	20.20	40.40	1,000
25P	56	26.20	52.40	1,000
30P	56	26.20	52.40	1,000

				JOINT TECH ELECTRONIC IND. CO., LTD. JOY DAY INDUSTRIAL CO., LTD.	
		UNIT	SCALE	SHEET	TITLE:
		mm		2 of 2	1.25mm PITCH 90° WAFER-SMT TYPE, WITHOUT BOSS TAPING SPEC.
		DRAWN BY	APPROVED BY		
		董正一	董正一		
		2004.10.28	2004.10.28		
B2	REVISE	2008.01.25	GENERAL TOLERANCE		
B1	REVISE	2007.01.03	X. X±0.25	ANGLE±	
B0	NEW RELEASE	2005.12.08	X. XX±0.15		
REV.	DESCRIPTION	DATE	X. XXX±0.05		
				DRAW NO. :	REV. B2
				A1253WR-S-XP	