

CAP
(FOR PICK AND
PLACE SYSTEMS)

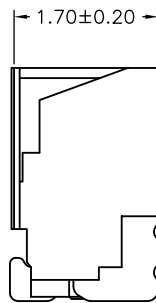
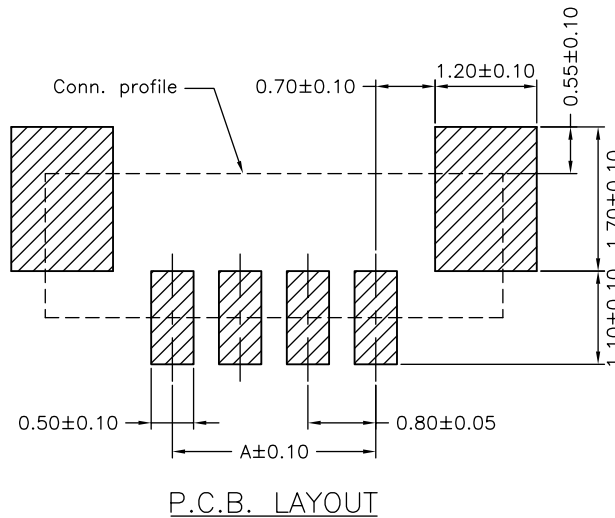
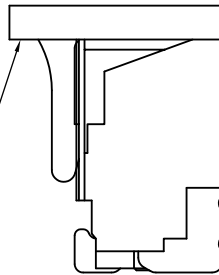
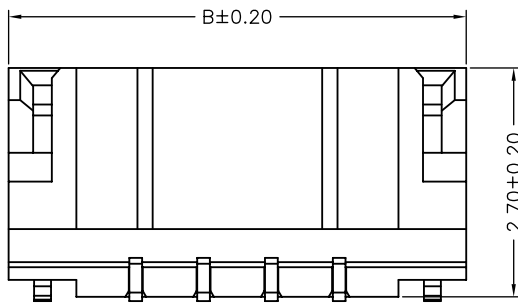
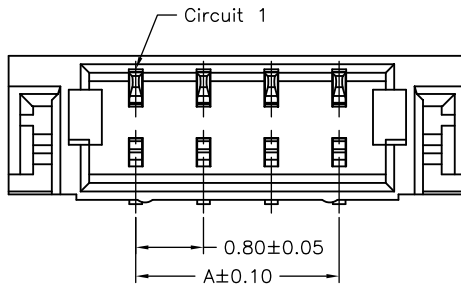
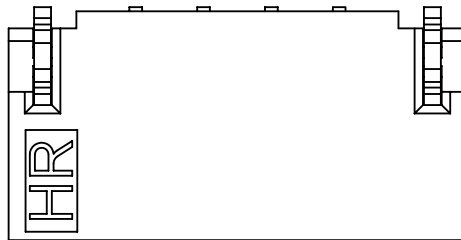
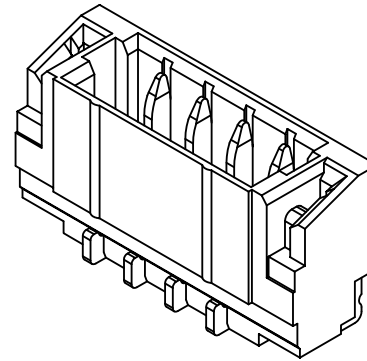

SPECIFICATIONS

Current Rating: 0.5A AC,DC
Voltage Rating: 30V AC,DC
Temperature Range: -25°C ~ +85°C
Contact Resistance: 20mΩ Max.
Insulation Resistance: 100MΩ Min.
Withstanding Voltage: 200V AC/minute
Pin Material: Phosphor Bronze/Tin-plated
Solder Tabs: Phosphor Bronze/Tin-plated
Material: Nylon 6T,UL94V-0
Cap: Nylon 6T,UL94V-0,Natural(Beige)
Color: Natural(Beige)

Ordering Information & Dimensions

PART NO.	Dimensions	
	A	B
A0800WV-S-02P	0.80	3.80
A0800WV-S-03P	1.60	4.60
A0800WV-S-04P	2.40	5.40
A0800WV-S-06P	4.00	7.00
A0800WV-S-07P	4.80	7.80
A0800WV-S-08P	5.60	8.60
A0800WV-S-10P	7.20	10.20
A0800WV-S-12P	8.80	11.80
A0800WV-S-14P	10.40	13.40
A0800WV-S-15P	11.20	14.20
A0800WV-S-16P	12.00	15.00
A0800WV-S-17P	12.80	15.80
A0800WV-S-20P	15.20	18.20

					JOINT TECH ELECTRONIC IND. CO., LTD. JOY DAY INDUSTRIAL CO., LTD.	
			UNIT	SCALE	SHEET	TITLE:
			mm		1 of 2	
A5	REVISE	2008.04.08	DRAWN BY	APPROVED BY		0.80mm PITCH 180° WAFER-SMT TYPE
A4	REVISE	2007.10.12	李勤	董正一		
A3	REVISE	2007.07.26	2006.02.07	2006.02.07		
A2	REVISE	2006.09.25	GENERAL TOLERANCE			
A1	REVISE	2006.04.15	X.X±0.25	ANGLE±		
A0	NEW RELEASE	2006.02.07	X.XX±0.15			
REV.	DESCRIPTION	DATE	X.XXX±0.05			DRAW NO. : A0800WV-S-XP
						REV. A5

02~03 Contacts

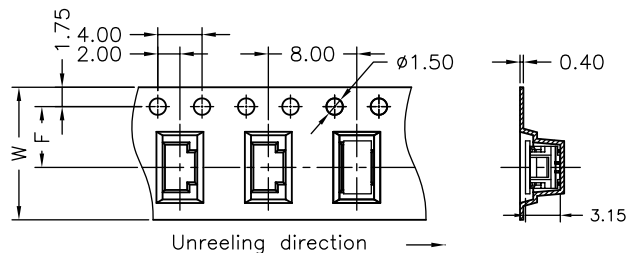

20 Contacts

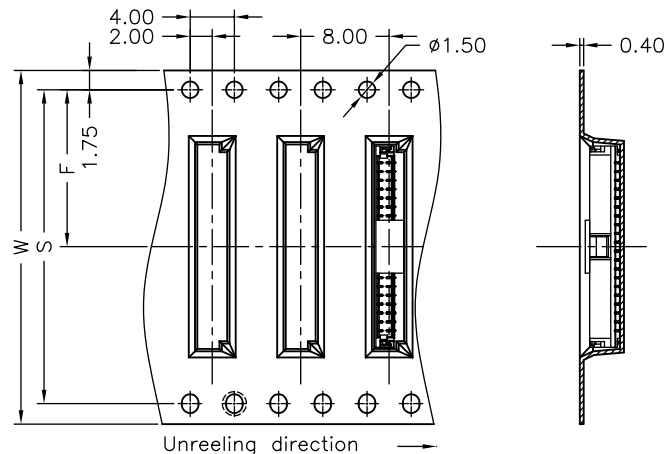

04~17 Contacts

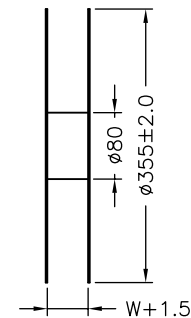
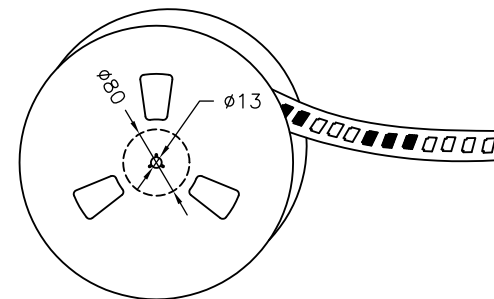
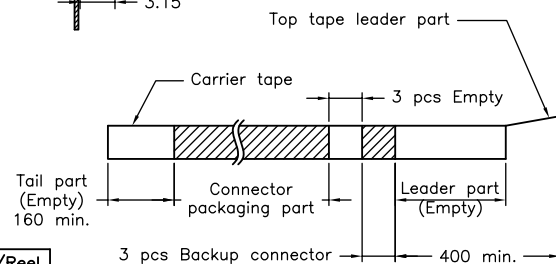
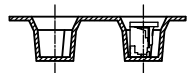
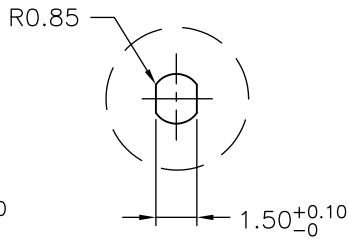
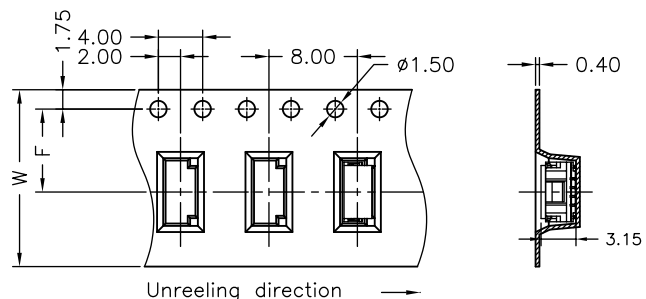

Number of Contacts	W±0.3	F±0.1	S±0.1	Q'ty/Reel
02P	16	7.50		2,000
03P	16	7.50		2,000
04P	16	7.50		2,000
06P	16	7.50		2,000
07P	16	7.50		2,000
08P	24	11.50		2,000
10P	24	11.50		2,000
12P	24	11.50		2,000
14P	24	11.50		2,000
15P	24	11.50		2,000
16P	24	11.50		2,000
17P	24	11.50		2,000
20P	32	14.20	28.40	2,000

			JOINT TECH ELECTRONIC IND. CO., LTD. JOY DAY INDUSTRIAL CO., LTD.	
		UNIT	SCALE	SHEET
		mm		2 of 2
		DRAWN BY		APPROVED BY
		歐陽小強		董正一
		2006.09.25		2006.09.25
		GENERAL TOLERANCE		
A3	REVISE	2008.04.08	X. X±0.25	ANGLE±
A2	REVISE	2007.10.12	X. XX±0.15	
A1	REVISE	2007.07.26	X. XXX±0.05	
A0	NEW RELEASE	2006.09.25		
REV.	DESCRIPTION	DATE		
DRAW NO. : A0800WV-S-XP				REV. A3

TITLE:
 0.80mm PITCH
 180° WAFER-SMT TYPE
 TAPING SPEC.