

CABLE ASSEMBLED CONDITION(REF.)

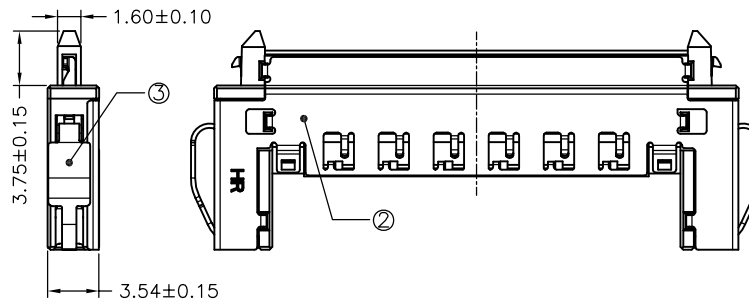
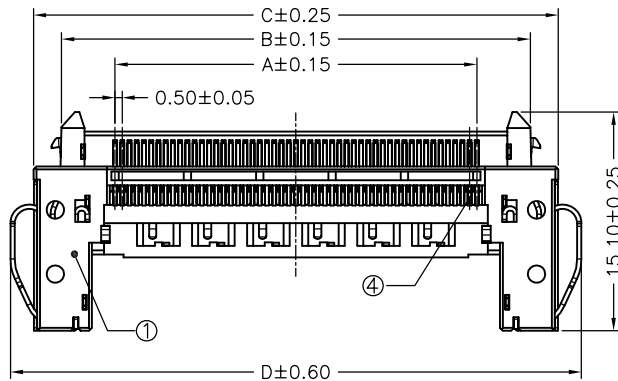

SPECIFICATIONS
 Current Rating: 0.7A AC,DC
 Voltage Rating: 100V AC,DC
 Temperature Range: -25°C ~ +85°C
 Contact Resistance: 50mΩ Max.
 Insulation Resistance: 100MΩ Min.
 Withstanding Voltage: 500V AC/minute

Ordering Information & Dimensions

PART NO.	Dimensions			
	A	B	C	D
A0505HA-21P	10.00	17.40	21.25	24.45
A0505HA-31P	15.00	22.40	26.25	29.45
A0505HA-41P	20.00	27.40	31.25	34.45
A0505HA-51P	25.00	32.40	36.25	39.45

No.	Description	Material	Color
1	Insulator	LCP,UL94V-0	Natural(Black)
2	Ground plate	Phosphor Bronze/Tin-plated	---
3	Lock lever	Stainless	---
4	Contact	Phosphor Bronze/ Gold-plated on contact area; Tin-plated on solder area	---

				JOINT TECH ELECTRONIC IND. CO., LTD. JOY DAY INDUSTRIAL CO., LTD.				
UNIT	SCALE	SHEET	TITLE:					
mm		1 of 1	0.50mm PITCH HOUSING- SOLDERING TYPE					
DRAWN BY		APPROVED BY				DRAW NO. : A0505HA-XP		
李權洲		董正一						
2008.05.29		2008.05.29				REV. A0		
GENERAL TOLERANCE			REV. A0					
X. X±0.25		ANGLE±				REV. A0		
X. XX±0.15			REV. A0					
X. XXX±0.05						REV. A0		
REV.	DESCRIPTION	DATE	REV. A0					
						REV. A0		