

CABLE ASSEMBLED CONDITION(REF.)

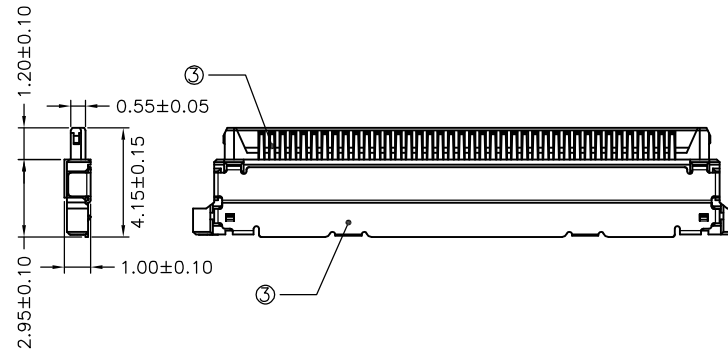
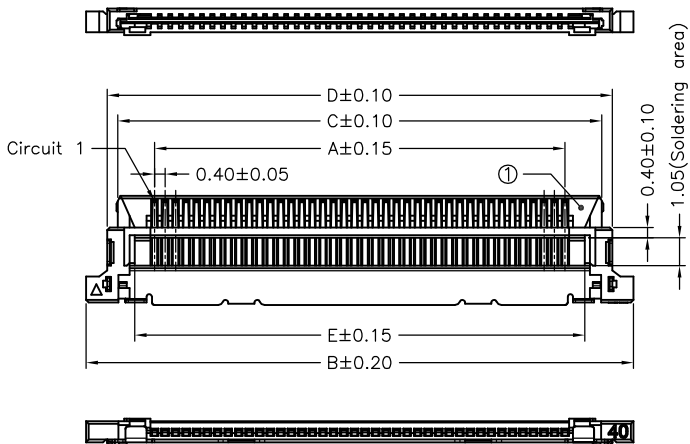

SPECIFICATIONS
 Current Rating: 0.3A AC,DC
 Voltage Rating: 100V AC,DC
 Temperature Range: -25°C ~ +85°C
 Contact Resistance: 40mΩ Max.
 Insulation Resistance: 1000MΩ Min.
 Withstanding Voltage: 250V AC/minute

Ordering Information & Dimensions

PART NO.	Dimensions				
	A	B	C	D	E
A0400H-30P	11.60	16.80	14.40	15.20	13.10
A0400H-40P	15.60	20.80	18.40	19.20	17.10

No.	Description	Material	Color
1	Insulator	LCP,UL94V-0	Natural(Black)
2	Ground plate	Phosphor Bronze/Tin-plated	---
3	Contact	Phosphor Bronze/Gold-plated	---

				UNIT	SCALE	SHEET	TITLE:
				mm		1 of 1	
DRAWN BY		APPROVED BY		0.40mm PITCH COAXIAL HOUSING WITHOUT LOCK TYPE			
童冠銘		董正一					
2009.02.05		2009.02.05					
GENERAL TOLERANCE				DRAW NO. : A0400H-XP			
X. X±0.25		ANGLE±					
X. XX±0.15		▽					
A0	NEW RELEASE	2009.02.05	X. XX±0.15	REV. A0			
REV.	DESCRIPTION	DATE	X. XXX±0.05				